

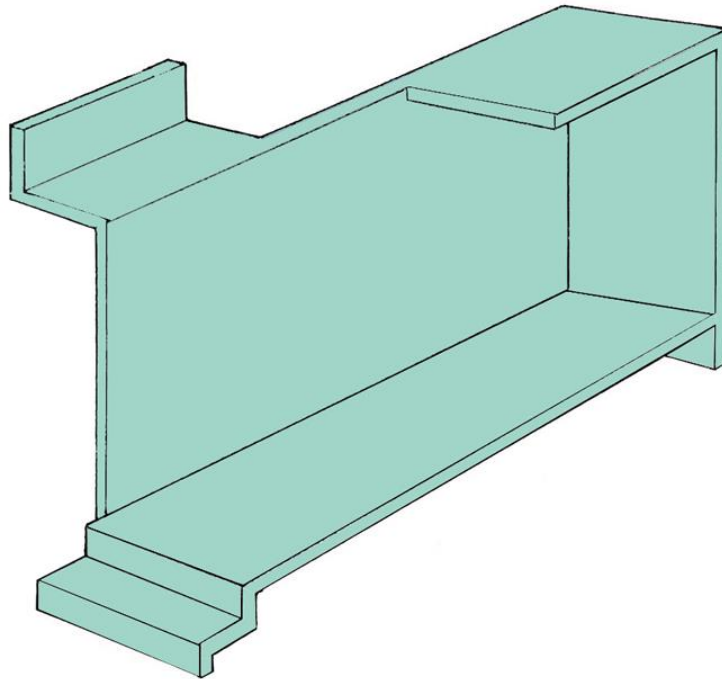

L'imprimerie
centre d'artistes



L'Écrin (the showcase)

Deadline : May 6, 2018

From June 2018 to April 2019, artists Caroline Boileau and Stéphane Gilot are taking over L'imprimerie's storefront—an adaptable exploration space overlooking Sainte-Catherine Street East—by integrating to it an architectural structure that is more creation laboratory than exhibition space. L'imprimerie's members are invited to take possession of this unique space by submitting proposals for installation works. All media are welcome: print, photography, drawing, sculpture and performance, with a strong focus on hybrid practices that use paper as primary material.

Artists who are up to the challenge will have to take into account the specific characteristics of this sculptural space in their proposal. They will also need to consider the storefront as an interface with the Hochelaga-Maisonneuve neighbourhood, and its potential interaction with passersby, both at night and in the daytime.

This project aims to connect artists-curators with L'imprimerie's members to develop original ways to showcase both existing and ongoing works. Each project will create an opportunity for discussions about the nature of art practices, what it means to present an exploratory work in the public space, and the role that constraints can play as both a driving force and a springboard for the artistic process.

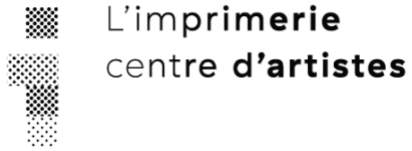

The centre will pay artists a \$375 fee and will be in charge of organizing the official launch of every new project.

Technical information

- Windows are equipped with a UV film to protect installations. Glass cannot be used for hanging or fastening.
- Proposals may integrate works from L'imprimerie's collection.
- Projects that evolve or change through time are encouraged.

Schedule — exploration time slots

- Slot 1: June—July 2018
- Slot 2: August—September 2018
- Slot 3: December 2018—January 2019
- Slot 4: February—March 2019

Applications must include:

- 15 digital images accompanied by a detailed list: max. individual file size 1 MB, in JPG format.
- CV, max. 3 pages
- Letter of intent — Project proposal for *L'Écrin*
- Preferred time slot/dates
- List of technical requirements for the project

Send your application to art@limprimerie.art, before 11:59 p.m. on May 6, 2018. Paper applications will not be considered.