

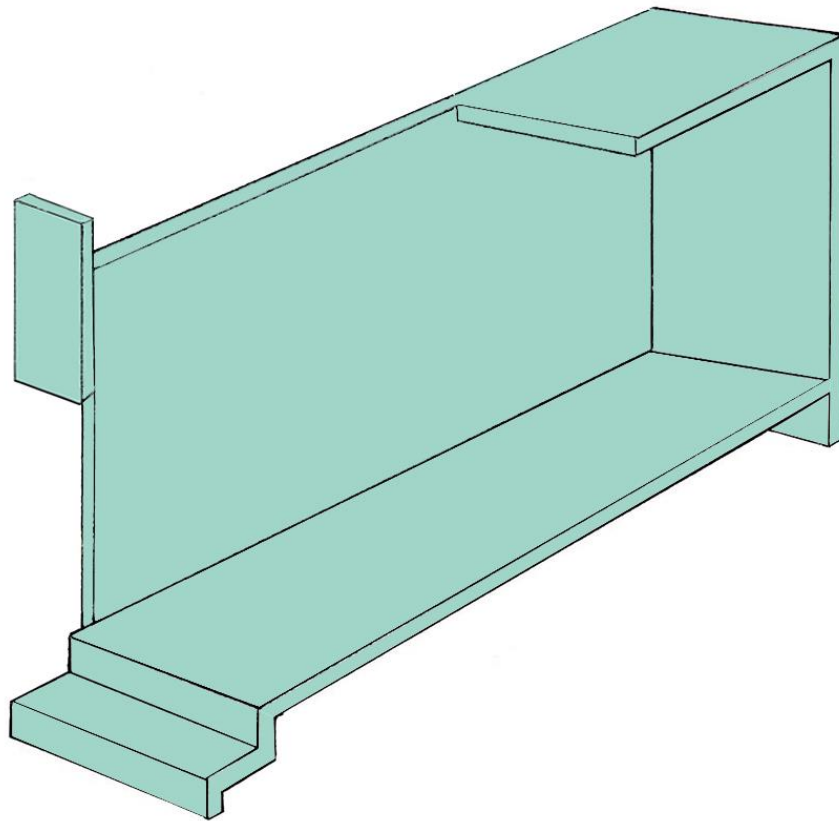

**L'imprimerie**  
**centre d'artistes**



## **L'Écrin 2019-2020**

**Deadline: May 6, 2019**

Since June 2018, artists Caroline Boileau and Stéphane Gilot are taking over L'imprimerie's storefront—an adaptable exploration space overlooking Sainte-Catherine Street East—by integrating to it an architectural structure that is more creation laboratory than exhibition space. L'imprimerie's members are invited to take possession of this unique space by submitting proposals for installation works. All media are welcome: print, photography, drawing, sculpture and performance, with a strong focus on hybrid practices that use paper as primary material.

Artists who are up to the challenge will have to take into account the specific characteristics of this sculptural space in their proposal. They will also need to consider the storefront as an interface with the Hochelaga-Maisonneuve neighbourhood, and its potential interaction with passersby, both at night and in the daytime. This project aims to connect artists-curators with L'imprimerie's members to develop original ways to showcase both existing and ongoing works.



Each project will create an opportunity for discussions about the nature of art practices, what it means to present an exploratory work in the public space, and the role that constraints can play as both a driving force and a springboard for the artistic process. Exploratory and evolving projects, deploying over time, will be privileged.

Some changes have been made for the second year of L'ÉCRIN: exploration and micro-residence time period will now be three months each.

The centre will pay artists a \$550 fee and will be in charge of organizing the official launch of every new project.

#### **Technical information**

- Windows are equipped with a UV film to protect installations. Glass cannot be used for hanging or fastening.
- L'imprimerie will offer a discount on certain services based on the needs of each project.

#### **Schedule — exploration time slots**

- Slot 1: September-November 2019
- Slot 2: February-April 2020
- Slot 3: May-July 2020

#### **Applications must include:**

- 15 digital images accompanied by a detailed list: max. individual file size 1 MB, in JPG format.
- CV, max. 3 pages
- Letter of intent — Project proposal for L'Écrin
- Preferred time slot/dates
- List of technical requirements for the project

Send your application to [art@limprimerie.art](mailto:art@limprimerie.art), before 11:59 p.m. on May 6, 2019. Paper applications will not be considered.